

# BESTORQ®

## V-Belt Installation, Maintenance & Storage

### Installation

1. Check pulleys for rust, oil, grease, dust, dirt and other foreign materials. Clean the pulleys. Foreign materials accelerate belt wear and dramatically reduce belt life. Dirt and dust lead to slippage. Oil and grease reduce belt traction and destroy the belt surface.

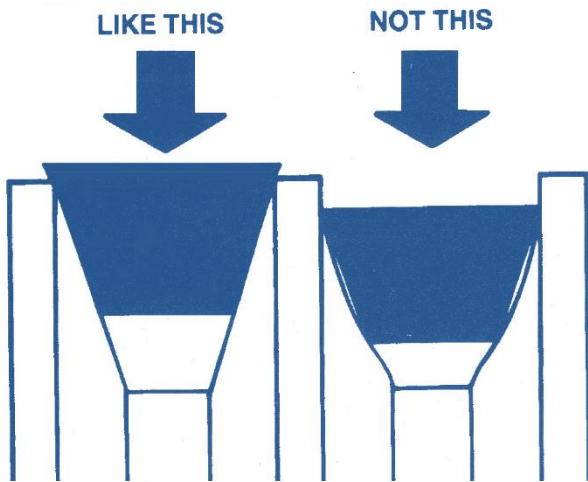
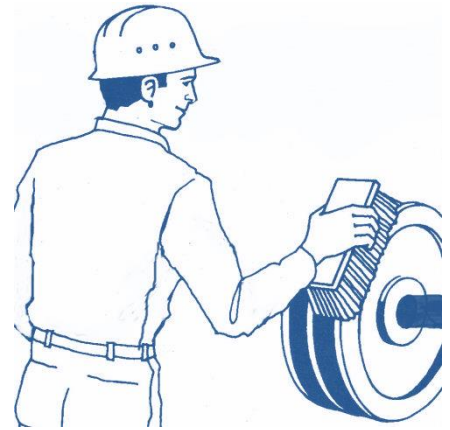

2. Inspect pulleys for wear. Worn pulleys greatly reduce belt life. Extreme wear can lead to belts bottoming in grooves. The result is slippage and excessive heat buildup. Use a pulley groove gauge to check for wear. V-belts should ride at least flush with the top of the pulley and may ride out up to 0.2". Check for burrs, nicks, gouges and severe scratches as these will drastically reduce belt life. Replace if necessary.

3. Check for proper alignment. Proper pulley alignment is critical to achieving maximum belt life. Misaligned pulleys lead to premature belt and pulley wear. As a general rule of thumb, misalignment should be less than .1" per 10" of span. Be sure to check for Angular and Axial Misalignment.

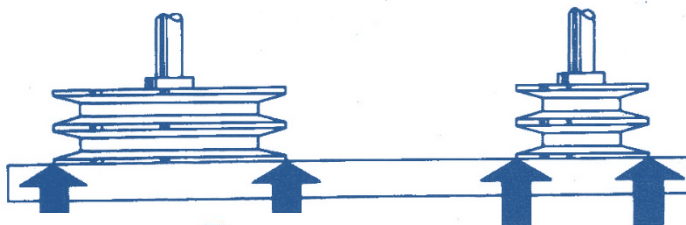
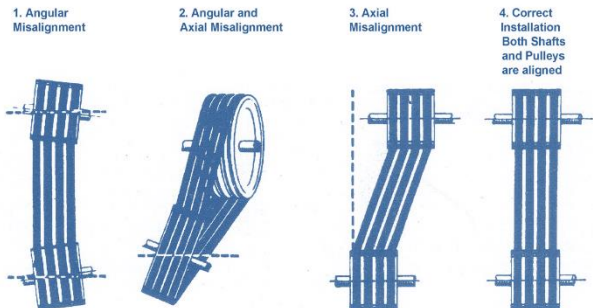

Use a straightedge to check drive alignment. All four points of the straightedge should contact the pulley. Use the straightedge in different positions to check for all kinds of misalignment. In multi-belt drives, misalignment can cause belts that are actually all the same length to appear different lengths. Extreme misalignment can cause rollover and severe belt wear.



4. Ensure all belts are the same. Do not mix belt brands. Do not mix belt constructions. (Such as raw edge, cogged, wrapped, single and banded) Do not mix new and used belts. The new belt or belts will carry the entire load. Do not mix used belts from different drives. Any mixed belts will cause the load to be carried unevenly, causing the belt carrying the majority of the load to fail rapidly, followed by the remaining belts.

# BESTORQ®

5. Place belts on the drive. Never force the belts into the pulley using a lever. Doing so can cause irreversible cord damage and/or fabric tearing. Always move the driver unit forward so the belts can be slipped into the pulley grooves without damage to the belts.

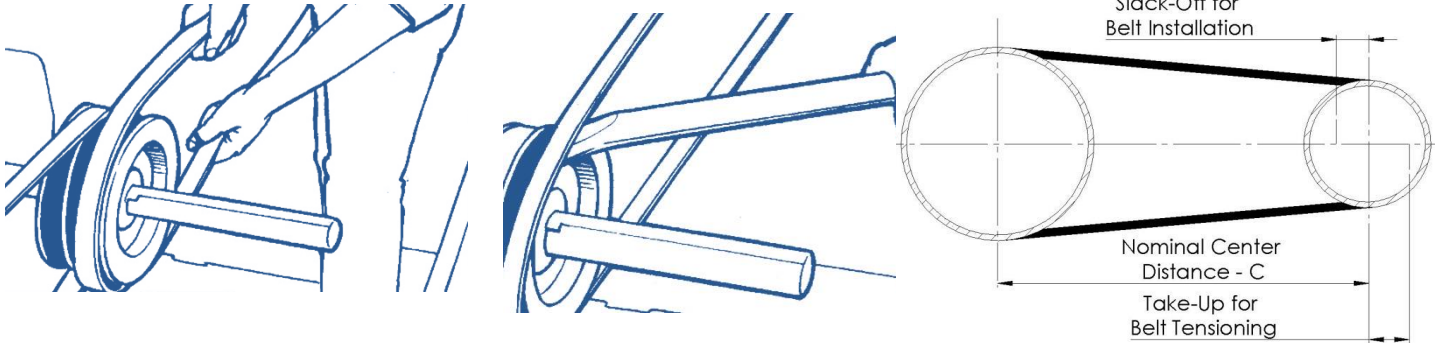

6. The nominal center distance should be determined from a standard pitch length and designed so that the centers can be moved closer together and farther apart to allow for installation and tensioning. The following tables are minimum allowances which allow for manufacturing tolerances as well as stretch and wear of belt. If the drive was designed following the guidelines below, there should be no problem installing or tensioning a belt of the correct length on the drive.

V-Belt Length Designation	Slack-Off for Installation (in)						Take-Up (in) All Cross Sections
	3V, 3VX Single Belts	3V, 3VX Banded Belts	5V, 5VX Single Belts	5V, 5VX Banded Belts	8V, 8VX Single Belts	8V, 8VX Banded Belts	
250 - 475	0.5	1.2	-	-	-	-	1.0
500 - 710	0.8	1.4	1.0	2.1	-	-	1.2
730 - 1060	0.8	1.4	1.0	2.1	1.5	3.4	1.5
1120 - 1250	0.8	1.4	1.0	2.1	1.5	3.4	1.8
1320 - 1700	0.8	1.4	1.0	2.1	1.5	3.4	2.2
1800 - 2000	-	-	1.0	2.1	1.8	3.6	2.5
2120 - 2360	-	-	1.2	2.4	1.8	3.6	2.8
2500 - 2650	-	-	1.2	2.4	1.8	3.6	3.2
2800 - 3000	-	-	1.2	2.4	1.8	3.6	3.5
3150 - 3550	-	-	1.2	2.4	2.0	4.0	4.0
3750 - 5000	-	-	-	-	2.0	4.0	5.5
5600	-	-	-	-	2.0	4.0	6.0

V-Belt Length Designation	Slack-Off for Installation (in)								Take-Up (in) All Cross Sections
	A, AX Single Belts	A, AX Banded Belts	B, BX Single Belts	B, BX Banded Belts	C, CX Single Belts	C Banded Belts	D Single Belts	D Banded Belts	
21 - 35	0.75	1.2	1.0	1.5	-	-	-	-	1.0
36 - 55	0.75	1.2	1.0	1.5	1.5	2.0	-	-	1.5
56 - 85	0.75	1.3	1.25	1.6	1.5	2.0	-	-	2.0
86 - 112	1.0	1.3	1.25	1.6	1.5	2.0	-	-	2.5
116 - 144	1.0	1.5	1.25	1.8	1.5	2.1	2.0	2.9	3.0
148 - 180	-	-	1.25	1.8	2.0	2.2	2.0	3.0	3.5
191 - 210	-	-	1.5	1.9	2.0	2.3	2.0	3.2	4.0
225 - 240	-	-	1.5	2.0	2.0	2.5	2.5	3.2	4.5
225 - 300	-	-	1.5	2.2	2.0	2.5	2.5	3.5	5.0
315 - 390	-	-	-	-	2.0	2.7	2.5	3.6	6.0
420 +	-	-	-	-	2.5	2.9	3.0	4.1	1.5% of belt

7. Attention to tensioning and pulley size is crucial in order to maximize belt life and optimize belt drive efficiency.
- Ideal tension is the lowest tension at which the belt will not slip under peak load conditions.
  - Belt tension should be checked and retensioned if necessary after a 24-48 hour run-in period.
  - Excessive tension shortens both belt and bearing life.
  - Periodically inspect V-belt drives. Adjust tension if belts are slipping. **Never apply belt dressing.**



## Tensioning

All belts do not feel the same when properly tensioned. There are two main groups of belts that feel quite different due to the materials and tension cables used in their manufacturing processes. The first group of belts feels spongy or springy when properly tensioned, while the second group of belts feel very rigid and stiff but still aren't properly tensioned. Bestorq and other major high quality manufacturers are in this second group of belts.

	Smallest Pulley Diameter Range	RPM Range	Belt Deflection Setting			
			uncogged belts		cogged belts	
			used belt	new belt	used belt	new belt
4L, A, AX	2.0 - 2.9	1000 - 2500	1.8	2.6	2.0	3.0
		2501 - 4000	1.4	2.0	1.6	2.4
	3.0 - 3.6	1000 - 2500	3.6	5.4	4.0	6.0
		2501 - 4000	2.8	4.1	3.3	4.9
	3.8 - 4.8	1000 - 2500	4.4	6.6	4.9	7.3
		2501 - 4000	3.7	5.7	4.3	6.4
	5.0 - 7.0	1000 - 2500	5.3	7.8	5.7	9.2
		2501 - 4000	4.6	6.8	5.1	7.6
5L, B, BX	3.4 - 4.2	860 - 2500			4.8	7.2
		2501 - 4000			4.1	6.2
	4.4 - 5.6	860 - 2500	5.2	7.9	7.1	10.5
		2501 - 4000	4.5	6.6	7.1	9.1
	5.8 - 8.6	860 - 2500	6.2	9.4	8.4	12.4
		2501 - 4000	6.0	6.8	7.3	10.7
C, CX	7.0 - 9.0	500 - 1740	11.3	17.0	14.7	21.9
		1741 - 3000	9.4	13.6	11.9	17.5
	9.5 - 16.0	500 - 1740	14.0	20.8	15.8	23.5
1741 - 3000		12.5	18.3	14.5	21.6	
D	12.0 - 16.0	200 - 850	24.7	37.1		
		851 - 1500	21.1	31.4		
	18.0 - 20.0	200 - 850	30.4	45.2		
		851 - 1500	25.6	38.0		
3V, 3VX	2.2 - 2.4	1000 - 2500			3.3	4.9
		2501 - 4000			2.9	4.3
	2.65 - 3.65	1000 - 2500	3.7	5.1	4.2	6.2
		2501 - 4000	3.0	4.5	3.8	5.6
	4.12 - 6.90	1000 - 2500	4.9	7.3	5.3	7.8
		2501 - 4000	4.3	6.6	4.8	7.3
5V, 5VX	4.4 - 6.7	500 - 1749			10	15.2
		1750 - 3000			8.9	13.2
	7.1 - 10.9	3001 - 4000			5.6	8.5
		500 - 1740	12.6	18.9	14.8	22.1
	11.8 - 16.0	1741 - 3000	11.2	16.5	13.7	20.1
		500 - 1740	15.5	23.4	17.1	25.5
	1741 - 3000	14.5	21.8	16.8	25	
8V	12.5 - 17.0	200 - 850	33	49.5		
		851 - 2100	27	39.9		
	18.0 - 22.4	200 - 850	39.5	59		
851 - 2100		35.1	52.8			
3VK	2.65 - 3.65	750 - 2500	5.6	8.3		
		2501 - 4000	4.5	6.8		
	4.12 - 6.90	1000 - 2500	7.4	11.0		
2501 - 4000		6.5	9.7			
5VK	7.1 - 10.9	200 - 500	21.0	31.5		
		500 - 1250	18.0	27.0		
		1251 - 1900	16.8	25.2		
	11.8 - 16.0	1901 - 3000	16.0	24.0		
		200 - 740	26.6	39.9		
		741 - 1250	23.3	34.9		
8VK	12.5 - 20.0	1251 - 2250	21.8	32.6		
		200 - 550	44.8	67.2		
		551 - 800	39.0	58.5		
	21.2 - 22.4	851 - 1150	35.6	53.4		
		1151 - 2100	33.6	50.4		
		200 - 550	66.0	99.0		
	551 - 850	62.0	93.0			
	851 - 2100	57.5	86.3			

Rigid belts stretch very little over their life and need to “feel” tighter than spongy belts which will actually stretch far more during their life. When tensioned properly, rigid belts will feel 1.5 to 1.8 times tighter than spongy belts. Although they feel tighter, rigid belts will not place any more load on bearings than spongy belts. The objective is to have the lowest tension to carry the load and yet high enough tension so there is never belt slip. Due to these different belt groups, one should not use “feel” to judge the correct tension of a belt. To more accurately tension V-Belt drives use the Force-Deflection Method shown below.

### Force-Deflection Method

1. Measure the span length P.
2. At center of the span length apply a force F (using a belt tension gauge) perpendicular to the belt span, large enough

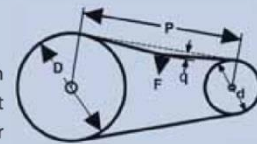

to deflect the belt 1/64" for each 1" of belt span, q. So, for a 32" span, the deflection amount would be 32/64" or 1/2".

3. The force F to apply is shown, per belt, in the table to the left. NOTE: The force shown in the table is per rib. So, for a 5-rib belt, you will need to multiply the force shown in the table by five to apply to all five ribs at once.

The successful operation of a belt drive is also highly dependent on the diameter of the pulleys involved. The Rubber Manufacturer's Association (RMA) has published minimum recommended pulley diameters for each belt profile. Using pulleys smaller than these recommended diameters will result in a dramatic increase in belt tension and substantially decrease the overall belt life.

### Minimum Recommended Pulley Diameters

Belt Type	Pitch Diameter	Outside Diameter
4L*	2.30	2.50
A	3.00	3.25
AX	2.20	2.45
B	5.40	5.75
BX	4.00	4.35
3V	2.65	2.65
3VX	2.20	2.20
5V	7.10	7.10
5VX	4.40	4.40

\*4L at this diameter has HP rating below 1/2 HP

See also: **Elongation Method of Tensioning** (useful for large banded belts) and **Normal V-Belt Tensioning** flyers which can be found at [Bestorq.com](http://Bestorq.com)

## Maintenance

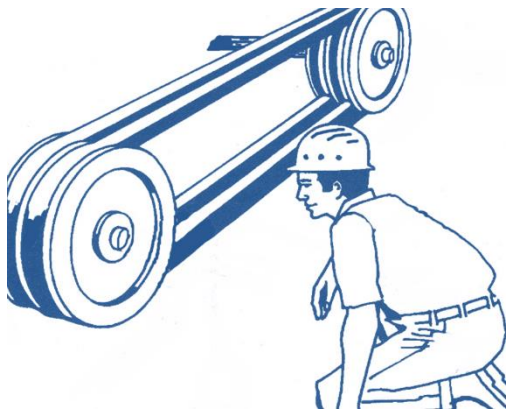

Properly installed belts generally do not require much maintenance. V-Belt drives are recognized as extremely reliable, trouble free and efficient. The main ingredient of good maintenance of a belt drive is to look and listen. Any of the following can be detrimental to belt life but if corrections are made and the belts have not been damaged, the drive will continue to perform well.

- **Dirt and Dust**

Dirt and dust accelerate belt wear. If too much dirt accumulates in the bottom of the groove it can cause the belt to bottom out and slip. Dusty conditions can reduce the belts grip on the sheave, leading to slip.

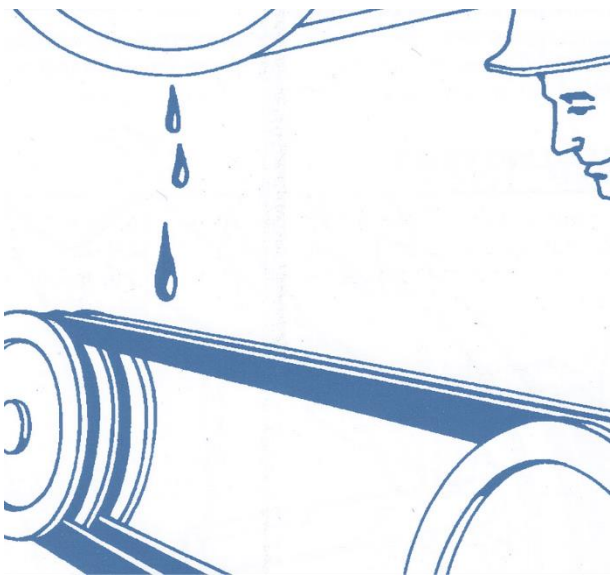
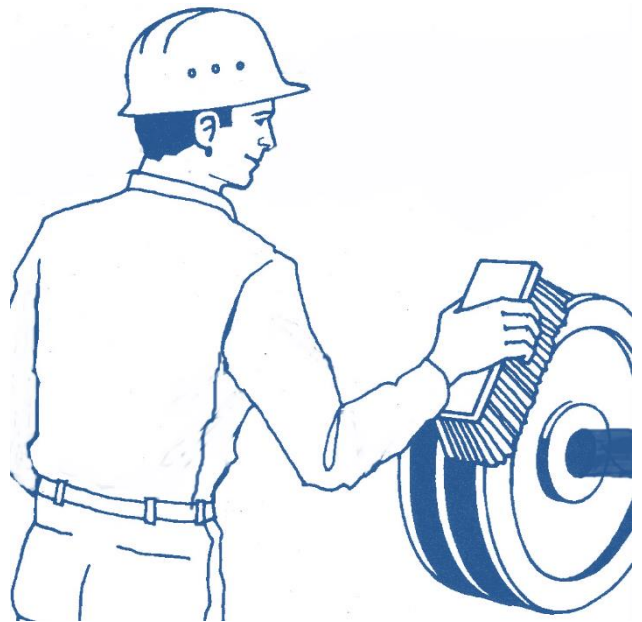

- **Oil & Grease**

Belts exposed to oil in a spray, liquid, or paste form tend to fail prematurely. Even belts labeled "Oil Resistant" are not designed to run in oily conditions. Oil breaks down the rubber either chemically or by causing slip, which rapidly destroys belts.

- **Added Loads**

Added loads will decrease belt life. Belt load versus belt life is not linear, so even small increases in belt loads can cause a severe reduction in belt life. Doubling the load on a belt could reduce the belts life to 5%-10% of the original. Always be sure to check that an added drive does not exceed the capabilities of another drive.

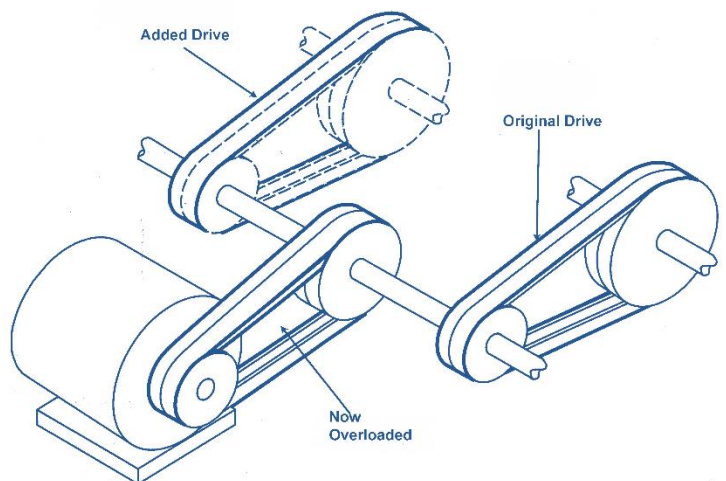



# BESTORQ®

- Squeal & Chirp

A squealing noise is an indication of belt slip and is most often due to insufficient belt tension. If the drive is properly tensioned (according to the table), the squealing could be due to dirt, oil, grease, misalignment or belt overload. If the cause of belt squeal is not found and eliminated, belt life will be dramatically reduced. A belt “chirp” sounds somewhat like a chirping bird, hence the name, and is often caused by misalignment. Dust can also be a contributing factor. Extremely wet or dry conditions can also cause chirp.

**Adding belt dressing will not fix the problem;** it will only degrade the surface of the belt and shorten belt life. Chirps are often annoying but do not significantly shorten belt life.

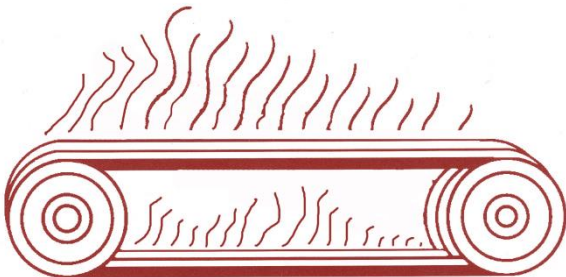
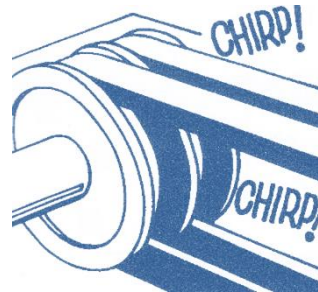
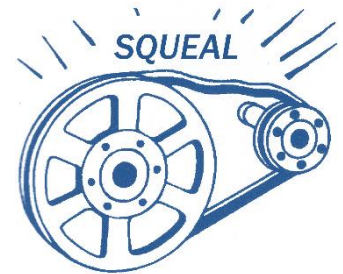

- Heat

Belts are cured in a scientifically controlled process. The rubber and other compounds used in belts are adversely affected by exposure to heat. Glazed sidewalls and cracks in belts are evidence that a belt has been damaged by heat. Heat may be from high ambient air temperature, belt slip or overload. The graph shows the approximate effects of ambient air temperature on belt life.

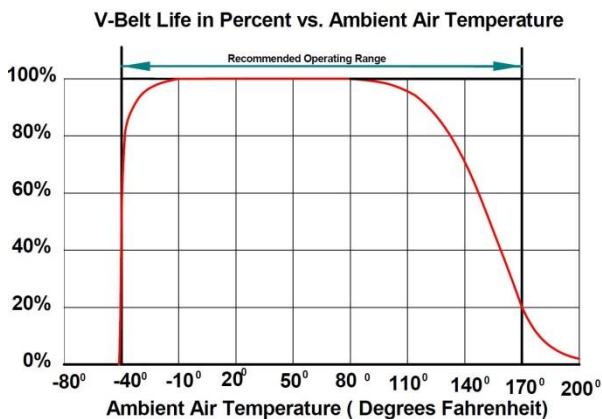

- Belt Turn Over

Belts which have rolled over may indicate: severe drive misalignment, badly worn pulleys, lateral vibration, foreign material or severe pulsating loads.

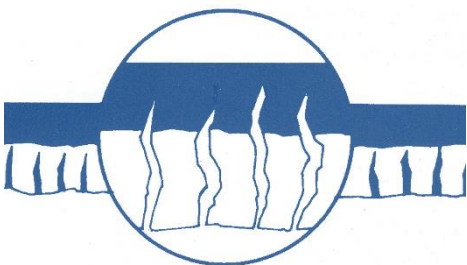
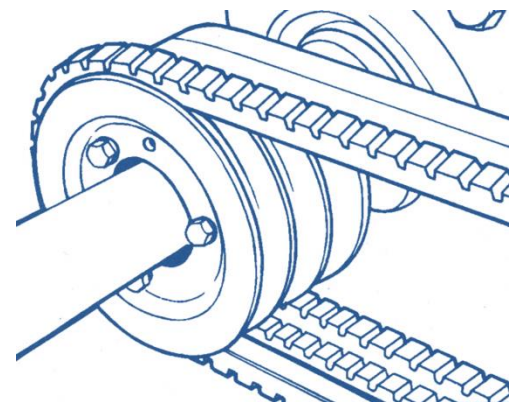

- Cracking

Bottom Cracking will not reduce the tensile strength of the belt nor will it affect the operation of the belt. Cracking will continue fairly rapidly and indicates a belt should be changed soon. High temperatures, dust, small diameters pulleys and backside idlers accelerate cracking.

# BESTORQ®

- Foreign Matter

The presence of foreign material in the drive can cause broken belts, rollover or excessive wear on both pulleys and belts.

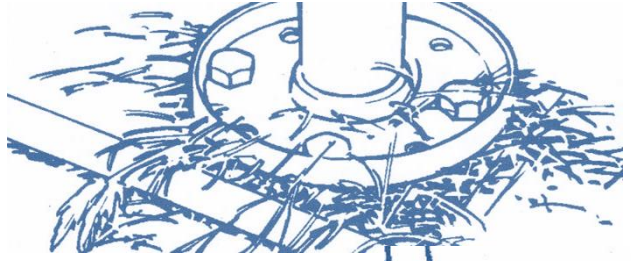

- Belt Dressing

As stated in the installation notes, **NEVER use any kind of belt dressing.** Belt dressing chemically attacks the surface of the belt to make it tacky and dramatically reduces belt life.



- Belt and/or Pulley Wear

If the belts are riding significantly different than the correct position, there is a drive problem to correct. Sheave wear, dust, dirt, misalignment, rough sheaves, slip, overloading and debris are common problems.

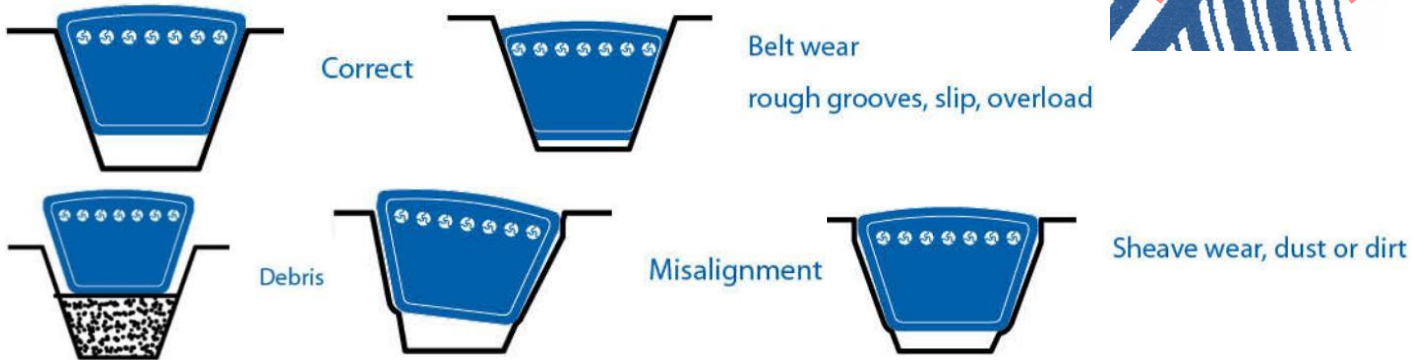

## Proper Storage

Proper care of a belt is not limited to the time during which the belt is operating on equipment; it also includes proper storage techniques. In order to prevent reduced belt life, proper storage techniques must be followed for all types of belts.

### Do's

- Belts should be stored in a cool and dry environment out of direct sunlight. Ideally, belts should be stored in conditions less than 85°F and 75% relative humidity. Adding 15°F to the storage temperature decreases belt life by approximately 50%. Do not store belts at a temperature above 115°F
- Storage on shelves in boxes or containers is recommended. If V-Belts are stored on a wall rack, use a saddle with a diameter at least as large as the minimum recommended sheave diameter for that cross section.
- Belts can be coiled as long as the diameter of the loops is not less than the minimum recommended sheave diameter for that cross section. Zero coils means one belt loop. One coil has three belt loops, etc. If belts are to be stored coiled, refer to the table for the maximum recommended number of coils for a given cross section.
- If stored in containers, ensure that the belt is not forced in and distorted. Limit the contents of each container so that the belts at the bottom are not damaged by the rest of the belts.
- If a machine will be idle for long periods of time (6+ months), the belt tension should be relaxed and the equipment or belt stored in an environment which meets the above guidelines.

### Don'ts

- Belts should not be stored near windows as this can expose the belts to moisture and sunlight. UV light causes the belt material to degrade and shorten belt life.
- Do not store belts near any type of heater, or in the direct airflow of a heating device. Belts should not be stored near any ozone generating device or where they are exposed to solvents or chemicals in the atmosphere.
- Do not store belts on the floor unless they are in a protective container. Floor locations are more likely to be exposed to traffic and chemicals that may damage the belts.
- Do not cause sharp bends or crimp belts. Crimping is when the belts are bent to a diameter smaller than that of the smallest recommended sheave diameter for that cross section. Hanging a belt on a small diameter pin or using a tie or tape near the "end" of the belts can cause irreversible damage to the tensile cord.
- Belts should not be exposed to excessive pressures or holding forces that cause permanent deformation.

Coiling Recommendations				
Belt Cross Section	Belt Length (in)	Belt Length (mm)	Number of Times Coiled	Number of Loops
3L, 4L, 5L, A, AX, AA, B, BX, 3V, 3VX	-60	-1500	0	1
	60 - 120	1500 - 3000	1	3
	120 - 180	3000 - 4600	2	5
	180+	4600+	3	7
BB, C, CX, 5V, 5VX	-75	-1900	0	1
	75 - 144	1900 - 3700	1	3
	144 - 240	3700 - 6000	2	5
	240+	6000+	3	7
CC, D	-120	-3000	0	1
	120 - 240	3000 - 6100	1	3
	240 - 330	6100 - 8400	2	5
	330 - 420	8400 - 10600	3	7
8V	420+	10600+	4	9
	-180	-4600	0	1
	180 - 270	4600 - 6900	1	3
	270 - 390	6900 - 9900	2	5
8V	390 - 480	9900 - 12200	3	7
	480+	12200+	4	9